

REPÈRE G : C12000047 - FERMETURE RIDELLE

REP.	CODE ARTICLE	DESIGNATION 1	QTY
1	E07000041	PAILLAGE LAT. DR160-180-200-280 EN NOIR	1
2	E02000090	BIELLE PAILLEUSE LATÉRALE DR	1
3	C02000025	BAGUE TY 30 X 34 X 25	4
4	C03000010	GRAISSEUR 6X100 STD + CHAPEAU PROTECT	4
5	E01000384	SUPPORT PAIL. LAT DR160	1
6	E03000076	AXE A PATTE COURTE BICH 30X255	2
7	D05000017	DENT PAIL. LAT Ø10 LG 370 DROITE	10
8	D01000506	DECOUPE LASER L1097 EP.6 BICH	10
9	C08000031	ECROU FREIN 985 CL 8 ZN 10 X 150	16
10	C08000044	ECROU FREIN 985 CL 8 ZN 8 X 125	2
11	C08000196	VIS TH ISO 4014 ZN 10X70 8.8	10
12	B05000112	UNION MALE 13G 3-8 GAZ CYL NU	2
13	D03000218	DECOUPE LASER L1094 EP.2 PLIEE STD	1
14	C08000735	VIS AUTOFOREUSE TH AC ZN 6.3X25	3
15	C08000360	VIS AUTOFOREUSE TH AC ZN 5.5X50	2
16	G02000038	BOUCHON Ø30 GPN 350 NAT	1
17	B06000177	VANNE 3 VOIES F3-8	1
18	C08000353	VIS TH ISO 4017 ZN 8X20 8.8	2
19	C08000304	VIS TH ISO 4017 ZN 10X25 8.8	2
20	C12000017	BRIDE DE FIX FLEXIBLE 3-8	2
21	C08000086	RONDELLE PLATE ZN L 6	2
22	C08000403	ECROU BAS ZN 10	1
23	C08000136	Vis CHC ISO 4762 8.8ZN M10X30	1
24	B05000088	TE MALE 13G 3-8 CO	1
25	B05000042	COUDE MALE 13G MALE 3-8 GAZ CO NU	2
26	C15000004	JOINT BS Ø17 3-8	2
27	G01000013	AUTOCOLLANT ACSE02	1
28	G01000003	AUTOCOLLANT ACEN01	4
29	B05000036	COUDE MALE 08 MALE 1-4 GAZ CO NU	1

Tolérances générales: (sauf indications)
 débit +/- 1mm usinage +/- 0.1mm pliage +/- 1° assemblage +/- 1mm

ALTEC Plan N°: --

Dess: LT1 Mat.: -- Traitement de surface: Brut

Date: -- Poids: 80.93kg -

Format: A3

Désignation: --
 Désignation2: PAILLAGE LAT. DR160-DR180

Code Article: A-001267 FEUILLE 1/1 Ech: 1:8 Ind: A

POUR LES DEMANDES CONCERNANT LES PIGNONS
OU LA CHAINE,
MERCİ DE PRECISER LE NOMBRE DE DENTS OU LE
NOMBRE DE MAILLONS

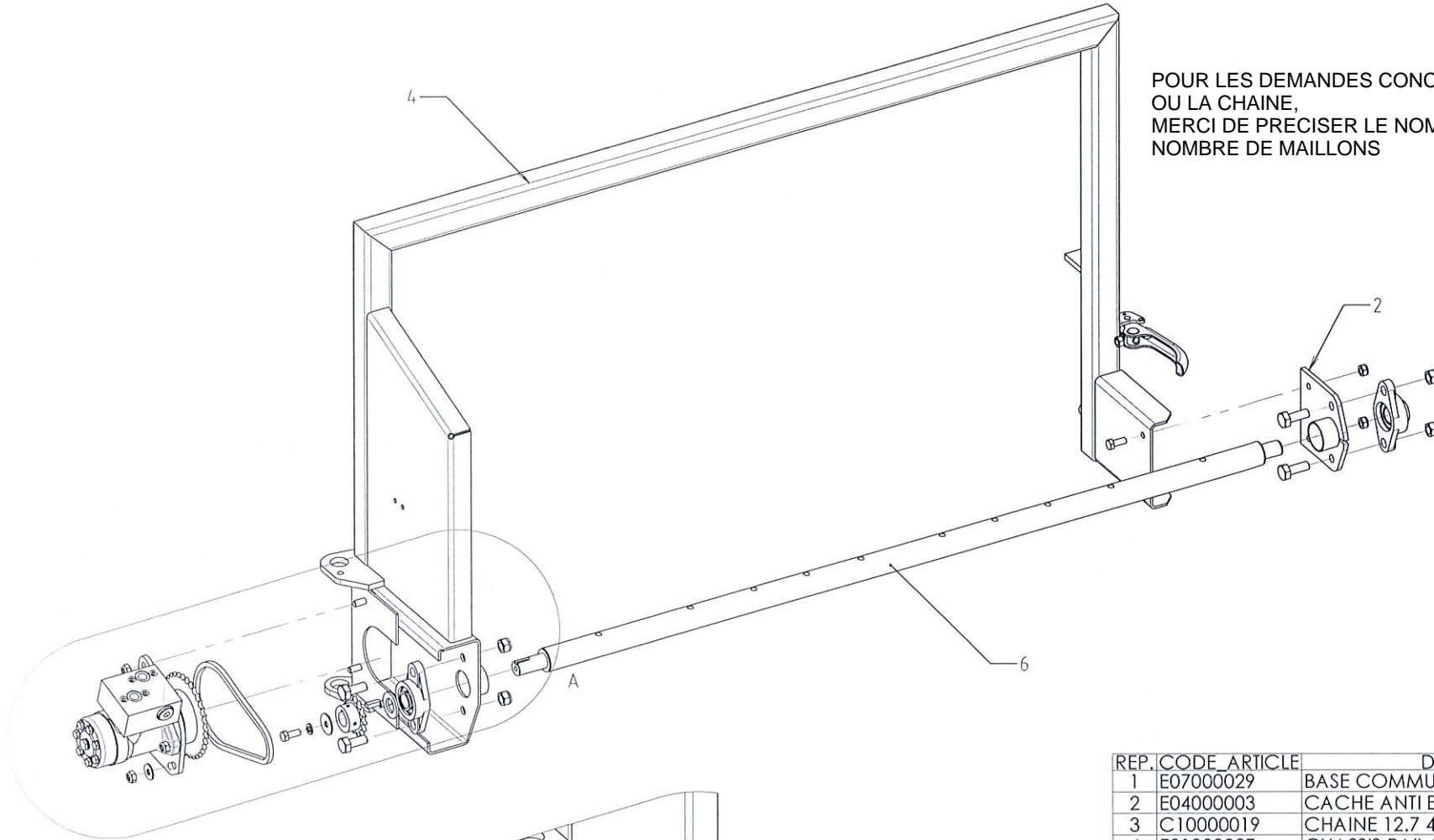

DÉTAIL A
ECHELLE 1: 5

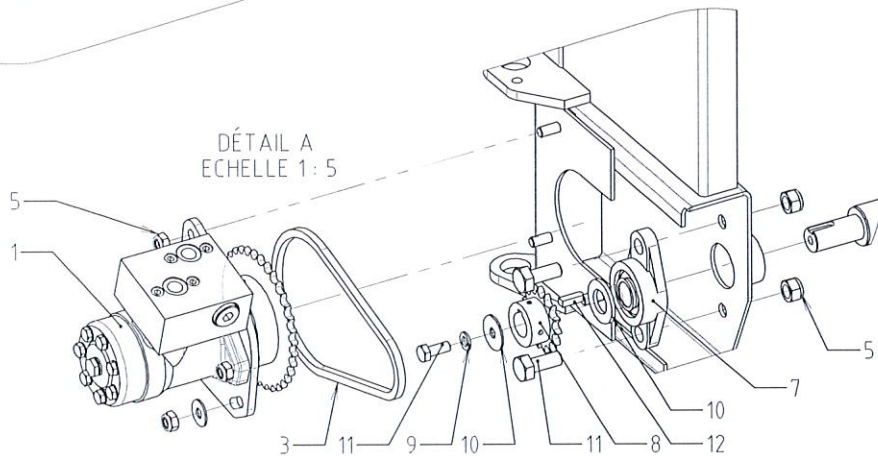

REP.	CODE_ARTICLE	DESIGNATION 1	QTE
1	E07000029	BASE COMMUNE MOTEUR PAIL LAT	1
2	E04000003	CACHE ANTI ENR PAIL LAT.	1
3	C10000019	CHAINE 12.7 47 MAILLONS+AR	1
4	E01000027	CHASSIS PAIL LAT DR - NU	1
5	C08000031	ECROU FREIN 985 CL 8 ZN 10 X 150	9
6	D02000733	ETIRE Ø 40 LG 1443	1
7	C04000003	PALIER APPLIQUE 25	2
8	C06000020	PIGNON SIMPLE 15 DTS 1-2 - Ø25+RC+VP	1
9	C08000055	RONDELLE GROWER 127 ZN 10	1
10	C08000115	RONDELLE PLATE ZN Z24	4
11	C08000304	VIS TH ISO 4017 ZN 10X25 8.8	7
12	C09000057	CLAVETTE BOUT ARRONDI-BOUT PLAT 8X7X25	1

Tolérances générales: (sauf indications) débit +/- 1mm usinage +/- 0.1mm pliage +/- 1° assemblage +/- 1mm			Désignation1: PAILLAGE LAT. DR160-180-200-280 EN NOIR
		Plan N°: E07000041	Désignation2: PAILLAGE LAT. DR160-180-200-280 EN NOIR
Dess: LT1	Mat.:	Traitement de surface:	Code Article E07000041
Date: 14-09-2018	Poids: 53.76kg	- Brut	
	Format: A3		Ech: 1:7 Ind.: B

REP.	CODE_ARTICLE	DESIGNATION 1	QTE
1	D02000735	DECOUPE LASER L770B EP.8 FRAISEE	1
2	B01000004	MOTEUR OMP 80	1
3	C08000581	VIS TFHC 7991 10.9 ZN 10 X 40	2
4	C08000031	ECROU FREIN 985 CL 8 ZN 10 X 150	2
5	B06000100	BLOC FORE DOUBLE CLAPET ANTI- RETOUR	1
6	C08000161	Vis CHC ISO 4762 8.8ZN M8X50	4
7	C06000038	PIGNON SIMPLE 35 DTS 1-2 - Ø25+RC+VP	1
8	D04000612	TUBE Ø 13X 1.5 LG 15	2

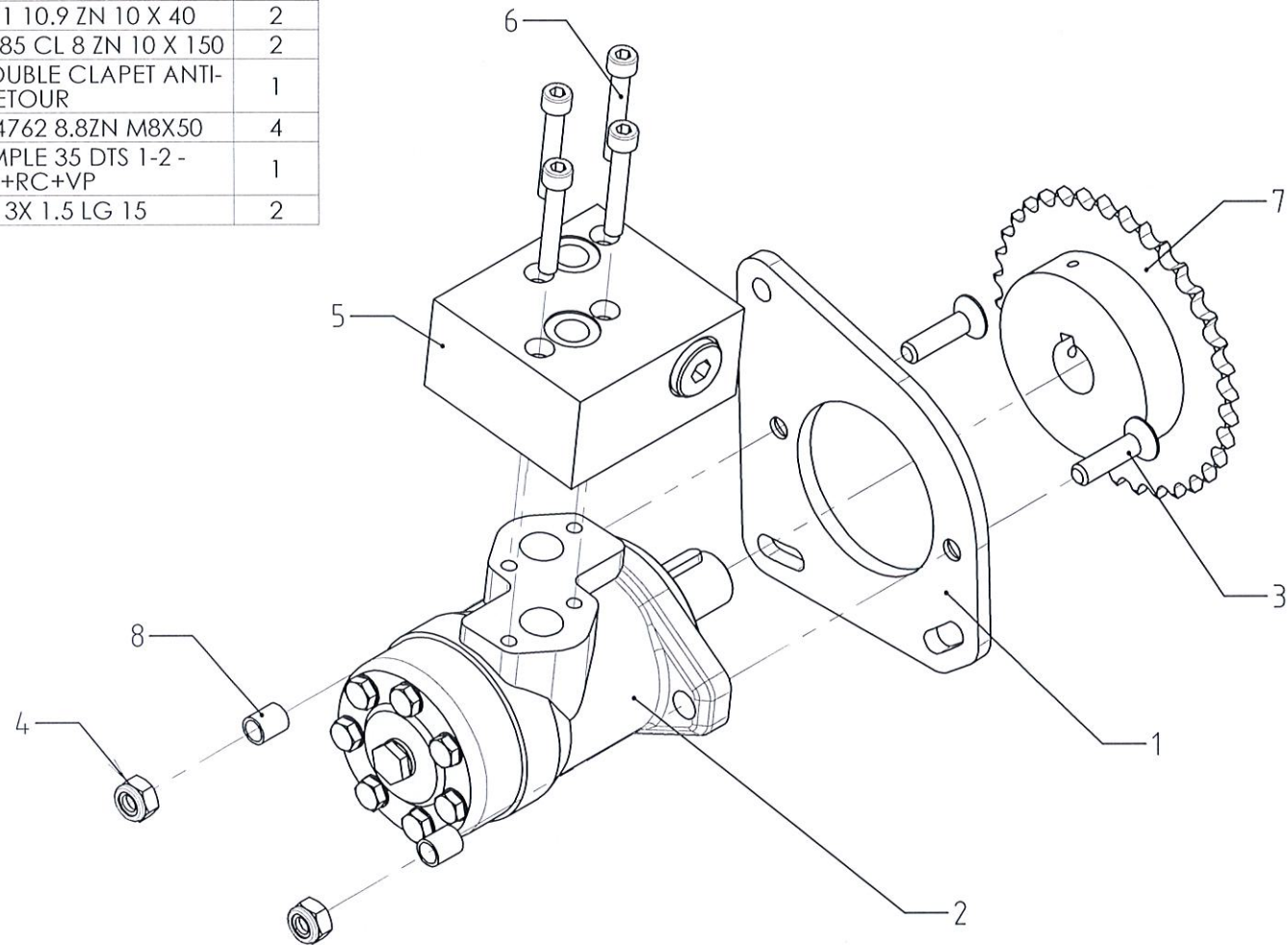

Tolérances générales: (sauf indications)
débit +/- 1mm usinage +/- 0.1mm pliage +/- 1° assemblage +/- 1mm



Plan N°:

-



Dess: Admin

Date:
11-01-2019

Mat.:

Poids: 10.59kg

Format: A4

Traitement de surface:

- Brut

-

Désignation1:
BASE COMMUNE MOTEUR PAIL LAT

Désignation2:

Code Article: E07000029

FEUILLE
1/1

Ech.: 1:3

Ind.: A